

## Bar Peeling

Through many decades of experience, Greenleaf Corporation has developed and demonstrated the technical ability to design and manufacture tooling and carbide to meet the ever present challenges facing the Bar Turning industry.

Utilizing engineering systems capable of advanced 3-D modeling and CNC manufacturing equipment, Greenleaf is one of the few cutting tool manufacturers to provide a Bar Turning solution from the machine spindle through the cutting tool insert...a complete tooling system engineered to meet your requirements.

A consultation with the Greenleaf engineering department is the first step when ordering new tooling or requesting a formal engineered quotation regarding your specific application. This will ensure the proper match among cutter head, cartridge and insert for the range of bar diameter and materials to be machined.

As an added benefit, the Greenleaf Technical Service Group will review and recommend the appropriate carbide grade and chipform to best ensure your productivity requirements are met or exceeded.

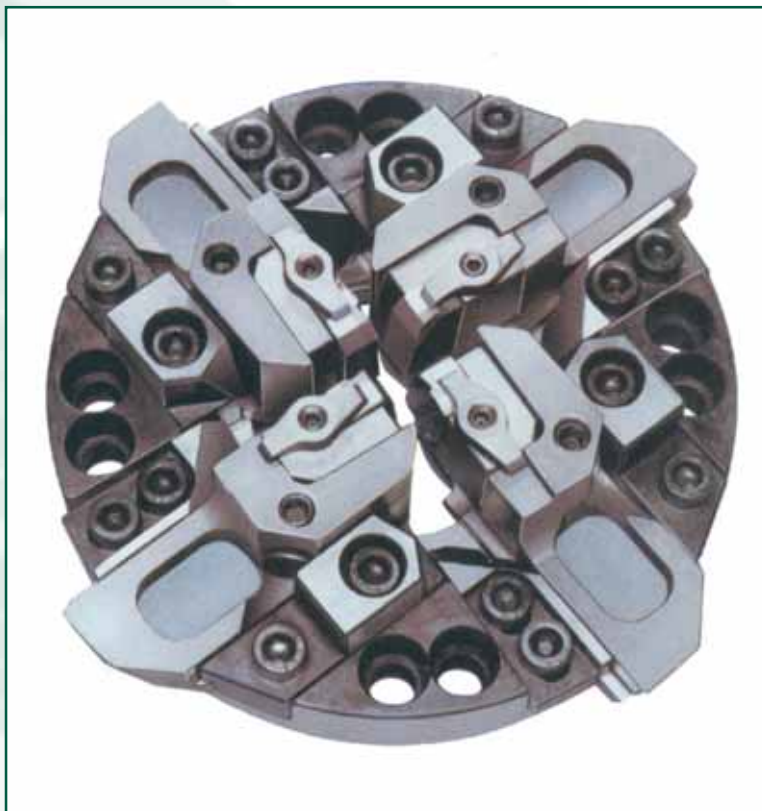

### **Greenleaf Sales**

Phone: 814-763-2915 • 800-458-1850 • Fax: 814-763-4423  
sales@greenleafcorporation.com • www.greenleafcorporation.com

## Kieserling Cutter Head

A consultation with the Greenleaf engineering department is suggested when ordering new tooling for the first time. This will ensure the proper match among cutter head, tooling, and insert style for the range of bar diameters being cut.

As an additional part of the consultation, Greenleaf technical service can recommend appropriate carbide grades.

Various tools/cartridges and inserts are available. The most widely used are shown here.

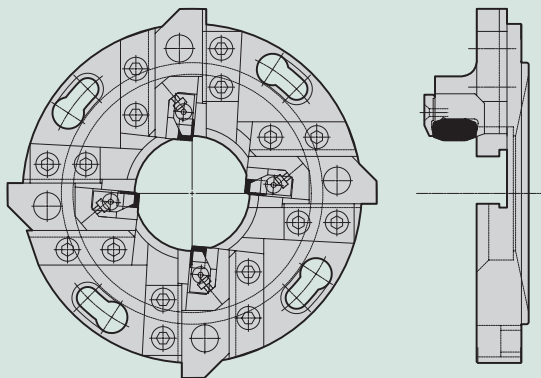

### Standard Double-Sided Insert

Insert Order Number	Dimensions (inches)		
	L	T	W
417037	1.457	0.473	0.709
<b>Other Options</b>			
409206			
420211			

### Heavy-Duty Single-Sided Insert

Insert Order Number	Dimensions (inches)		
	L	T	W
427150	1.428	0.470	0.710

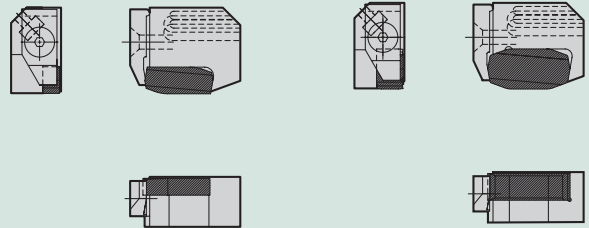

## Medart/Blaw Knox Cutter Head

A consultation with the Greenleaf engineering department is suggested when ordering new tooling for the first time. This will ensure the proper match among cutter head, tooling, and insert style for the range of bar diameters being cut.

As an additional part of the consultation, Greenleaf technical service can recommend appropriate carbide grades.

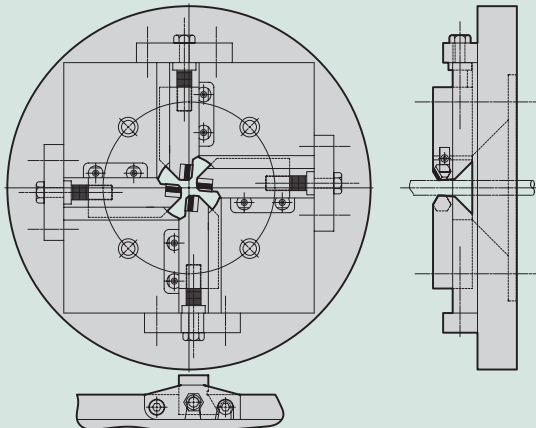

### INSERTS

**TNG-64MH**  
*precision ground*  
**TNU-64MH** *utility*

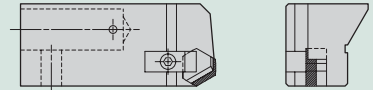

**305231** *square*  
**305232** *octagon*

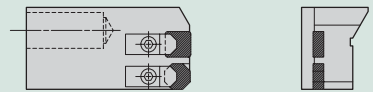

**417037** *standard*  
**409206** *optional*  
**420211** *optional*

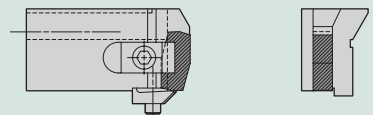

**419258** *round*

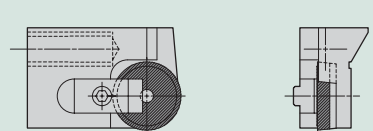

**420226** *1.125 I.C. Trigon*

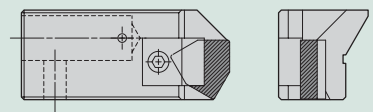

### Greenleaf Sales

Phone: 814-763-2915 • 800-458-1850 • Fax: 814-763-4423  
sales@greenleafcorporation.com • www.greenleafcorporation.com

## HeTRAN Cutter Head

A consultation with the Greenleaf engineering department is suggested when ordering new tooling for the first time. This will ensure the proper match among cutter head, tooling, and insert style for the range of bar diameters being cut. As an additional part of the consultation, Greenleaf technical service can recommend appropriate carbide grades.

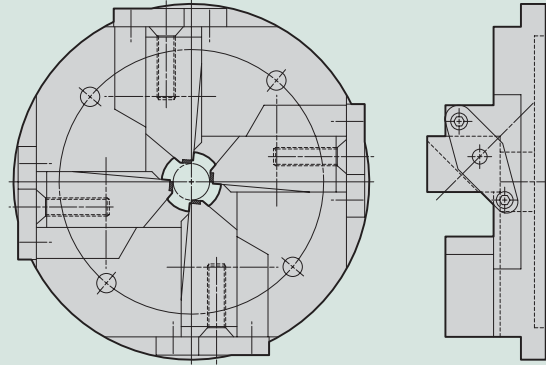

### INSERTS

**TNG64MH** precision ground — **TNU64MH** utility

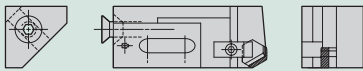

**420226** 1.125 I.C. Trigon

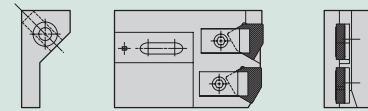

**305231** square — **305232** octagon

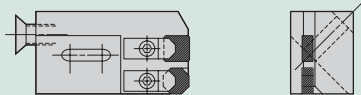

**420151** .750 I.C. Trigon

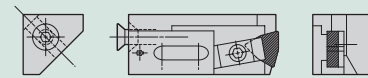

## Daisho Cutter Head

A consultation with the Greenleaf engineering department is the first step when ordering new tooling or requesting a formal engineered quotation regarding your specific application. This will insure the proper match between cutter head, cartridge and insert for the range of bar diameter and materials to be machined.

As an additional benefit, the Greenleaf Technical Service Group will review and recommend the appropriate carbide grade and chipform to best insure your productivity requirements are met or exceeded.

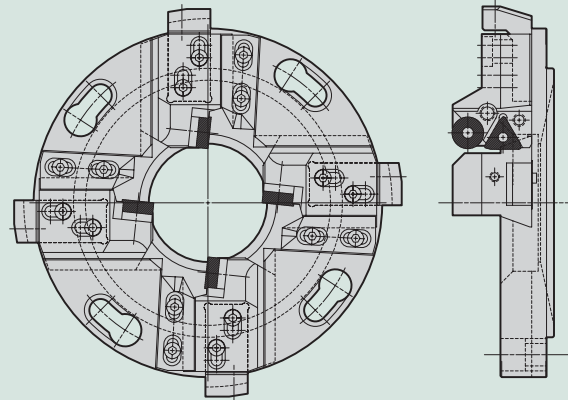

### INSERTS

**419866** triangle — **419867** round

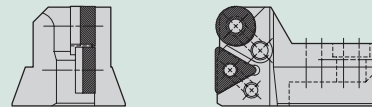

## Insert Geometries

**305231**

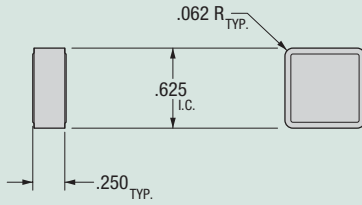

**420151**

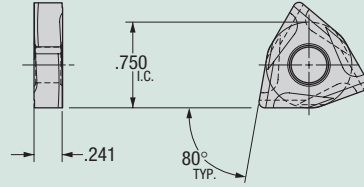

**305232**

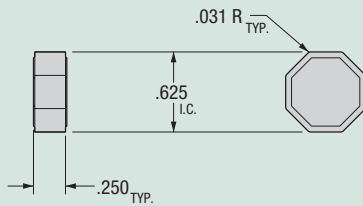

**420226**

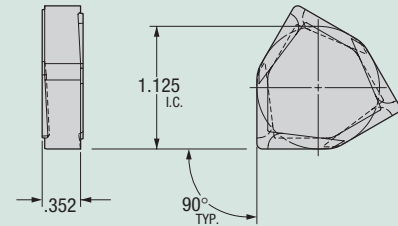

**409206** (.025 x 5° Land)

**417037** (.035 x 5° Land)

**423644** (.035 x 7° Land)

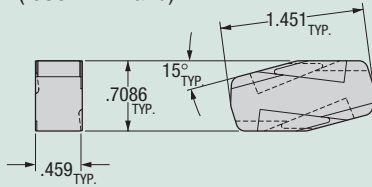

**423380** (.025 x 5° Land)

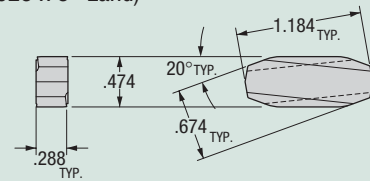

**427150**

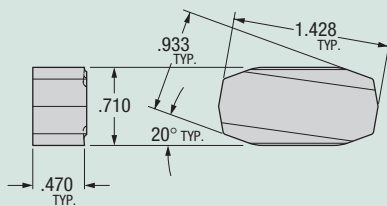

**423387** (.035 x 5° Land)

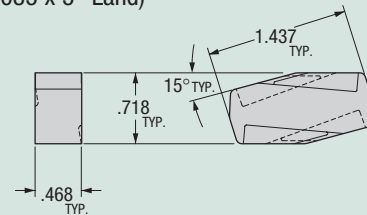

**414828**

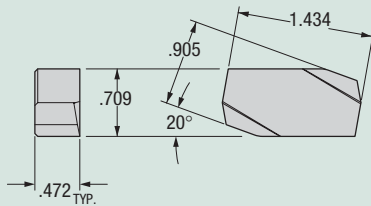

**423474** (.040 x 5° Land)

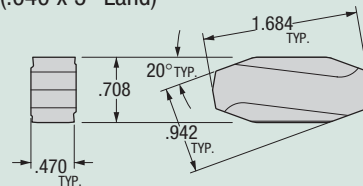

**Greenleaf Sales**

Phone: 814-763-2915 • 800-458-1850 • Fax: 814-763-4423  
sales@greenleafcorporation.com • www.greenleafcorporation.com

## Insert Geometries *continued*

**423480** (.040 x 5° Land)

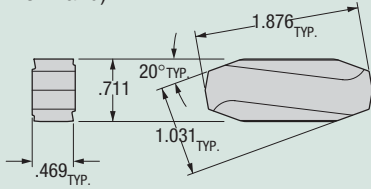

**423495**

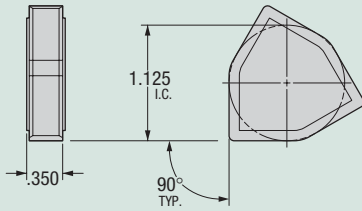

**423877**

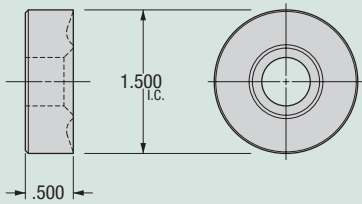

**423961** (No Land)

**423996** (.035 x 5° Land)

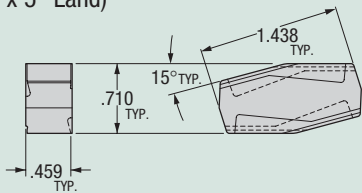

**TNG-64MH**

